

LAVAL UNDERGROUND SURVEYS

# DW-1500/ DW-2000 OPERATION MANUAL

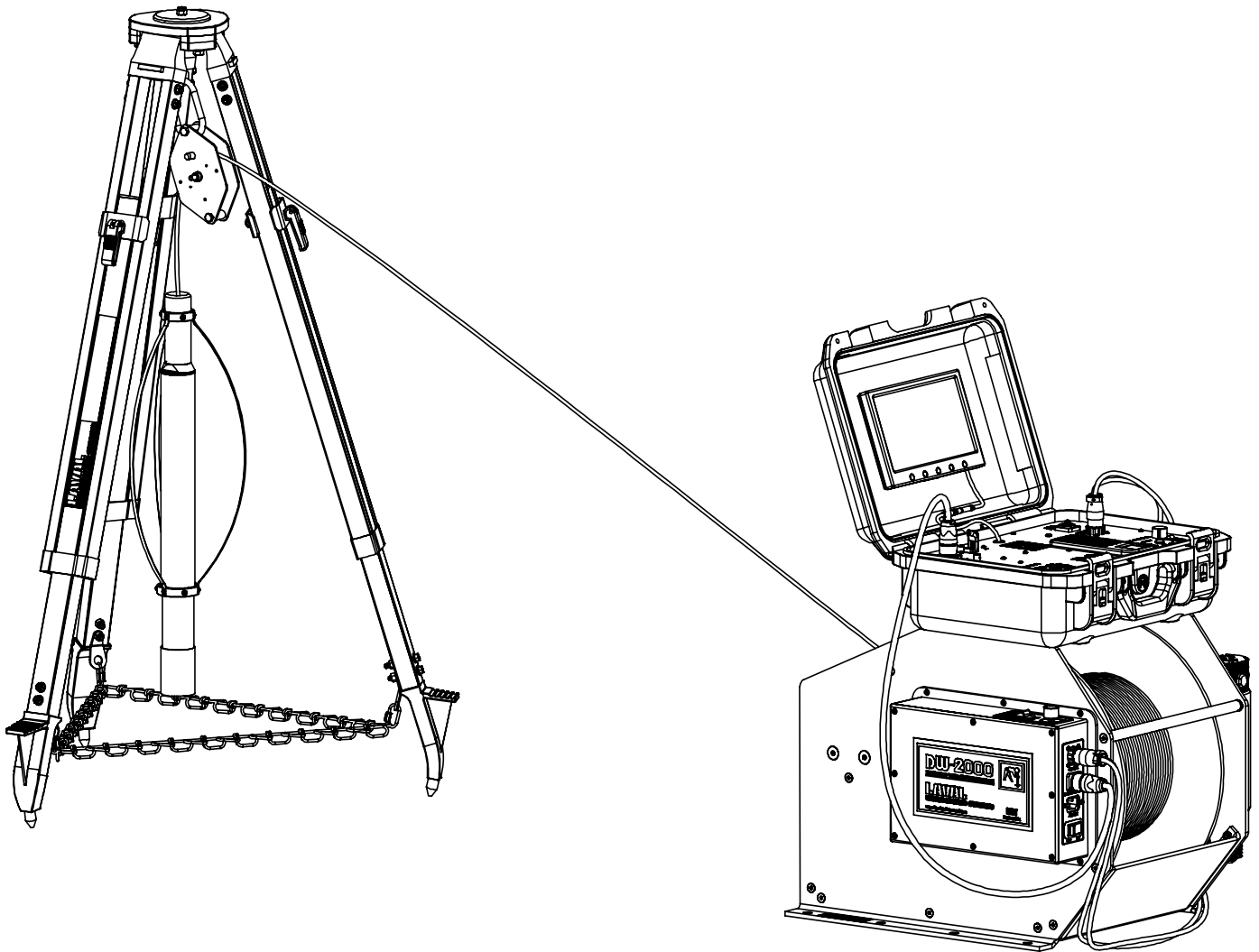
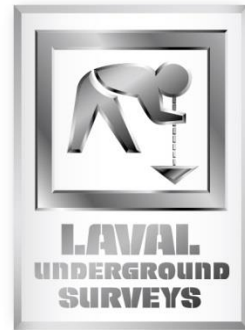

LAVAL UNDERGROUND SURVEYS  
2476 North Bundy Drive, Fresno Ca. 93727  
Phone 559-251-1396 · Fax 559-251-2096  
[www.lavalunderground.com](http://www.lavalunderground.com)

# Table of Content

System Unpack and Check.....	1
Operating Checklist .....	1
Before Starting Setup .....	1
Connecting the Camera.....	2
System Start Up.....	3
Tripod and Sheave Mounting .....	5
CAUTION/ATTENTION .....	6
Maintenance Instructions .....	7
Description of Equipment.....	8
Overall .....	8
Camera .....	8
Winch .....	10
Counter-Sheave Assembly.....	10
Control Unit.....	11
Winch Motor Control Functions.....	13
Adjustments .....	13
Level-Wind Adjustment.....	14
Level-Wind Key Replacement.....	15
DVR Guide .....	16
Keyboard Functions.....	17
Getting Started .....	17
Play Video.....	18
View Snapshots .....	18
Overlays.....	18
File Management .....	19
Setup .....	20
Helpful DVR Tips.....	22
Counter Instructions.....	23
Preset Mode.....	23
Position Mode .....	23
Standard Mode.....	24
CAL by Reel Mode .....	24
CAL by CNT/REV Mode .....	24
Status Mode .....	25
Water Well Clarification .....	26
Trouble-Shooting.....	28
WARRANTY.....	30

## System Unpack and Check

Carefully unpack the shipment and check the unit for the following:

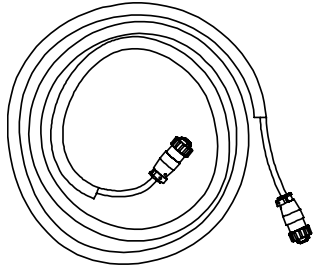

Control Cable

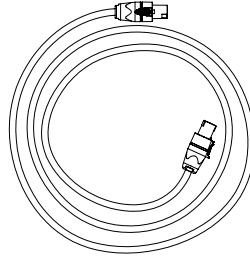

12 Volt Power Cable

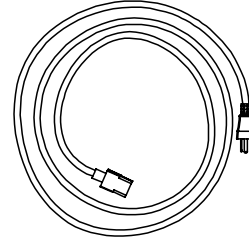

Winch Power Cable

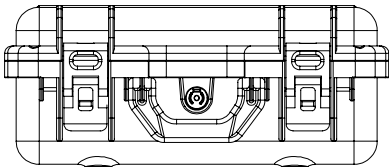

Control Unit

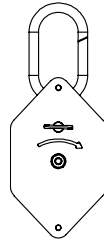

Tripod Sheave

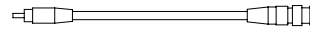

BNC-RCA Cable

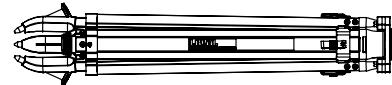

Tripod (Collapsed)

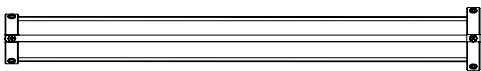

Centering Bands  
(with Collars)

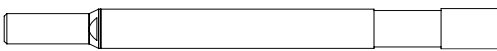

Camera

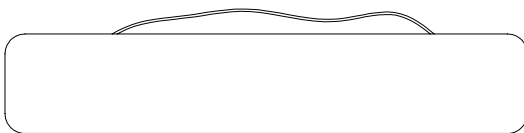

Camera Case

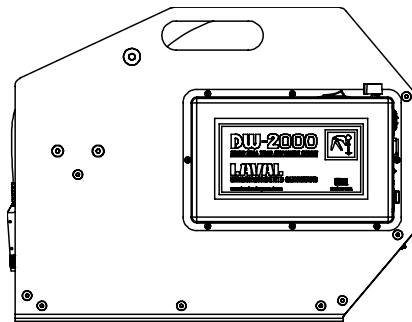

Winch

### Optional Accessories

(Sold Separately)

See [www.lavalparts.com](http://www.lavalparts.com)  
for more details

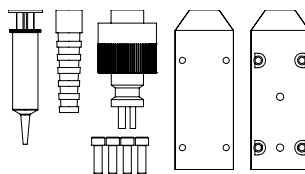

Cable Head Repair Kit

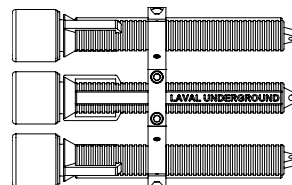

TriLight



Lens Shield

## Operating Checklist

### Before Starting Setup

1. Unpack the Winch (Figure 1 Item 1) and place the Winch on a stable surface, or bolt the frame to a secure platform using appropriately rated anchors.
2. Place Control Unit (Figure 1 Item 2) within 2 feet of the Winch on a flat secure surface.
3. Make sure the power is off by flipping the Power Switch (Figure 2 Item 6), located on the Winch Motor Controller (Figure 1 Item 3), to the OFF position.
4. Connect the Control Cable (Figure 1 Item 4) from the Control Unit (Figure 5 Item 2) to the Winch Control Connector (Figure 2 Item 3).
5. Connect the Power Cable (Figure 1 Item 5) from the Control Unit 12 VDC input (Figure 5 Item 1) to the 12 VDC output on the Winch (Figure 2 Item 4).
6. Insert the Power Cord into the Power Plug on the Winch (Figure 2 Item 5).
7. Turn the Speed Dial (Figure 2 Item 2) all the way to MIN.
8. Set up your Tripod (Figure 1 Item 6) or E-Z Over (not shown) on or over the hole for surveying.
9. Flip the Power Switch on the Winch to the ON position (Figure 2 Item 6).
10. Flip the Winch Control Switch (Figure 2 Item 1) to the FORWARD position and turn the Speed Dial (Figure 2 Item 2) slowly towards the MAX.
11. Run out enough cable to feed through the Tripod or E-Z Over so that the Camera (Figure 1 Item 7) when connected is centered above the hole.

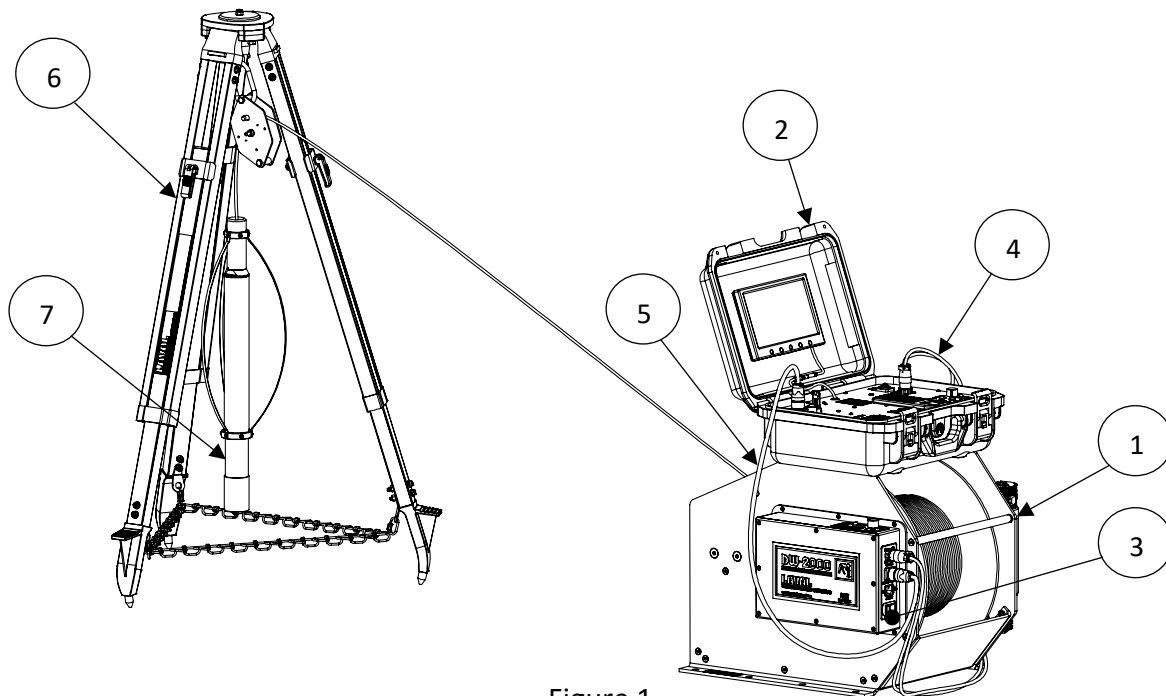

Figure 1

Note: All accessories are shown, please follow applicable instructions only

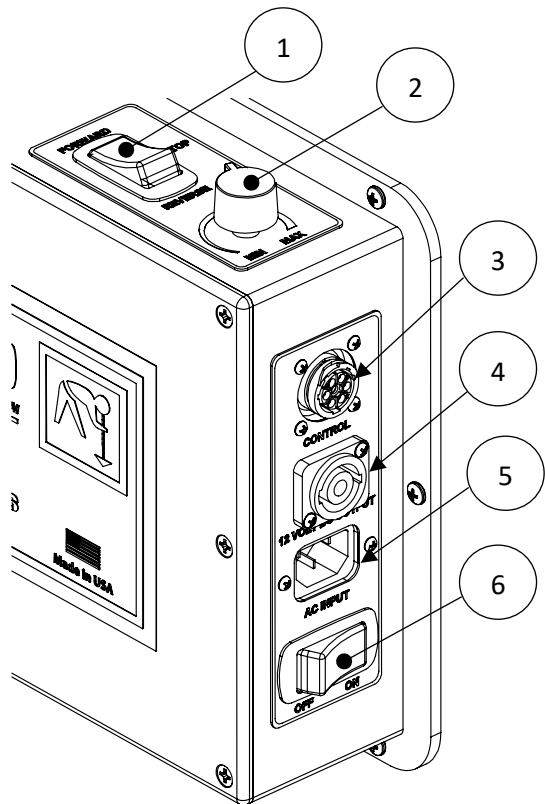

Figure 2

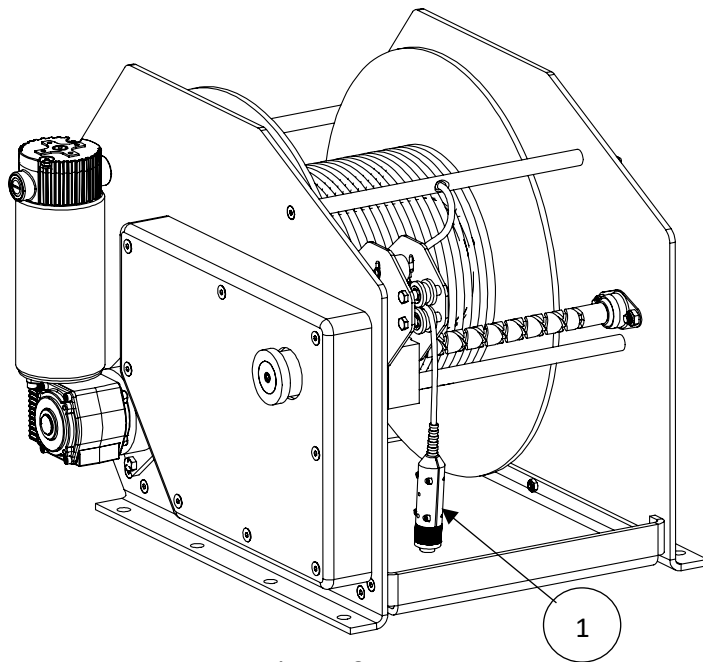

Figure 3

## Connecting the Camera

1. Position the Winch Power Switch to OFF (Figure 2 Item 6).
2. Before connecting the Camera to the Cable head Connector (Figure 3 Item 1) inspect the O-rings in both connectors to be sure they are clear of debris or any contamination. Also check for any wear or damage. The O-rings should also be re-lubricated on a regular basis. Use a NEMA-rated O-rings lubricant.
3. Slide the Centering Band Assy (Figure 4 Item 1) and Upper Support Tube (Figure 4 Item 2) beveled end first, over and past the Cable head (Figure 3 Item 1). Connect the Twist Locking Cable head Connector to the Camera by carefully aligning the keyway on the connectors together and twisting the lock until seated. **The cable head connector should only be hand tightened. Never over tighten the connectors or upper support tube.**
4. Thread the Upper Support Tube to the top of the Camera. Position the Lower Centering Band Collar on the Camera Housing (Figure 4 Item 3) at least  $\frac{1}{2}$ " above the Side View Port (Figure 4 Item 4) **DO NOT ATTACH THE CENTERING BAND COLLAR TO WITHIN  $\frac{1}{2}$ " OF THE GLASS PORT.** Position the Upper Collar on the Upper Support Tube so that the Centering Bands are extended to approximately  $\frac{1}{2}$  inch less than the diameter of the well or borehole being inspected.

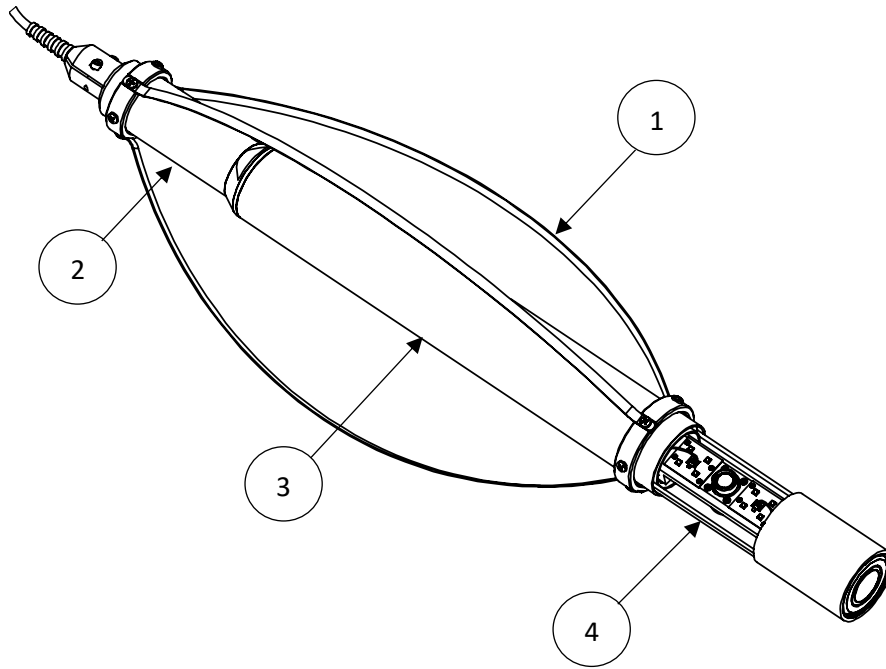

Figure 4

## System Start Up

1. Position the Camera Control Power Switch to ON (Figure 5 Item 3), on the Control Unit. Position the Winch Power Switch to ON (Figure 2 Item 6), on the Winch Motor Controller.
2. Turn on the LCD Monitor. While watching the Monitor to verify operation Switch between side and down view and adjust light intensity, with the VIEW-LIGHT Switch (Figure 5 Item 5). The LED lighting should light up with the view selected. The light intensity of the view selected can be changed by pressing LIGHT; this will cycle through 5 light intensity levels. Check the rotation by using the Cam Control FORWARD-REVERSE Switch (Figure 5 Item 4); both the Down View and Side Views will rotate.

**NOTE: The Reel Control on the Control Unit does not operate the Winch. The Winch Motor Controller and switches on the winch operate the Winch.**

3. Rewind any excess cable by using the Winch Motor Controller functions (Figure 2) to position the Camera in the well, near the top. Press the Camera Control CLEAR Switch (Figure 5 Item 6) to reset depth counter to zero (000.00f).
4. Ensure the wireless keyboard is plugged into the Keyboard USB Input (Figure 5 Item 7) and the supplied USB Flash Drive is installed into the Recording USB Input (Figure 5 Item 8). Press **R** on the wireless keyboard to begin recording. Press **S** at any time to capture a

snapshot. Press **ESC** to stop and finalize the recording. (See Keyboard Functions Section on page 13)

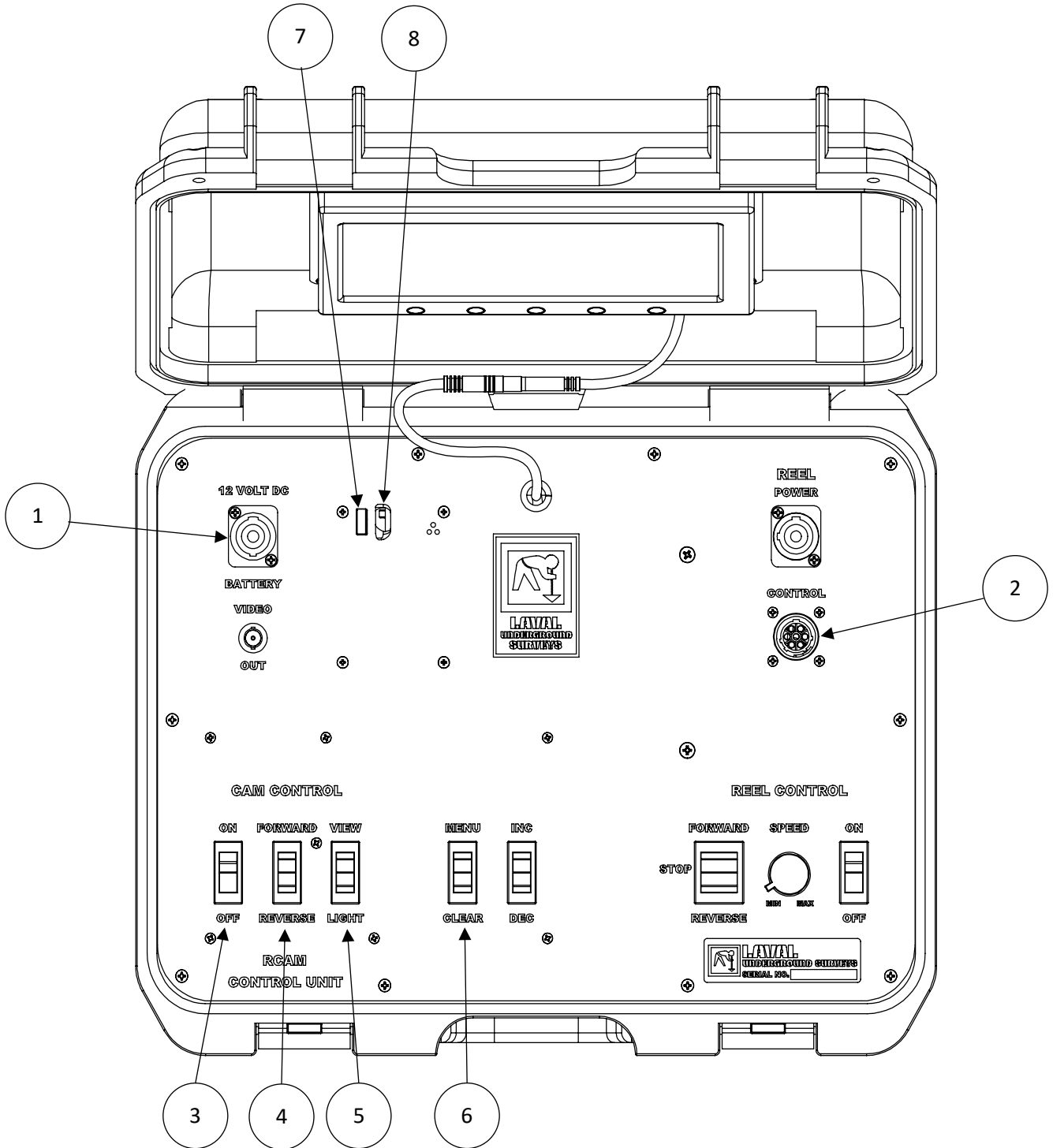

Figure 5

## Tripod and Sheave Mounting

1. Extend the three Tripod legs (Figure 6 Item 1) fully away from the center of the unit until it is in a stable position. The Sheave Assembly (Figure 6 Item 2) is mounted to the center eyebolt with the use of a Mounting Clip (Figure 6 Item 3).
2. Remove the Quick Release Pin (Figure 6 Item 4) by pulling it out of the Sheave Assembly. Thread the camera cable through the Sheave Assembly following the direction of the arrow. Lay the cable over the Sheave Wheel in the center with the cable head in the direction of the arrow.
3. Place the Quick Release Pin (Figure 6 Item 4) back into position to trap the cable, once the Mounting Clip (Figure 6 Item 3) is clipped to the assembly.
4. Adjust the length of legs by lifting the red Lock (Figure 6 Item 5) and sliding each leg to the desired length. Lower the red Lock back to lock the leg in place.

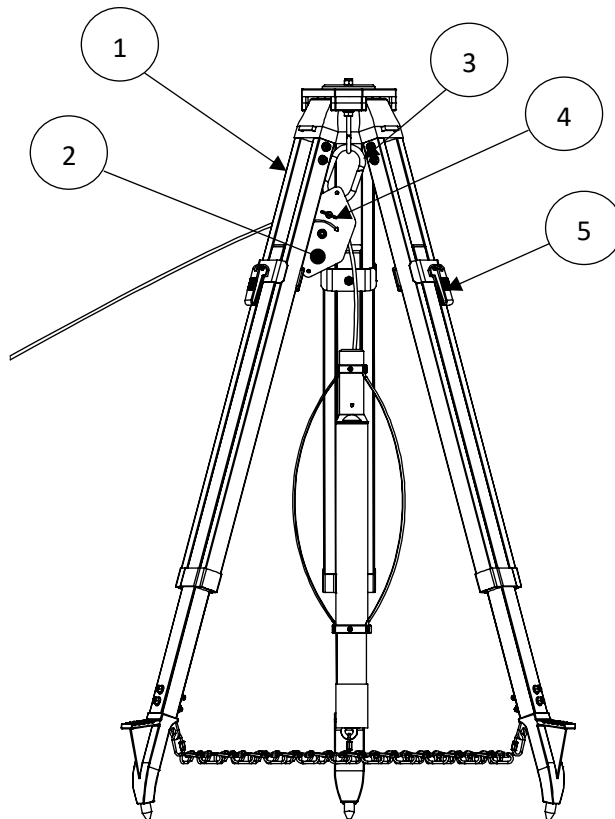

Figure 6

**NOTE: For this Tripod and Sheave, the camera is required to be connected after feeding the Cable Head (Figure 3 Item 1) through the Sheave Assembly. Ensure power is OFF (Figure 5 Item 3) before disconnecting the camera.**



## CAUTION/ATTENTION

1. **NEVER POINT THE DOWN HOLE OR SIDE VIEW CAMERAS DIRECTLY AT THE SUN EITHER WHILE ON OR OFF**
2. **DO NOT** connect or disconnect the Camera with the Control Unit CAM CONTROL **ON-OFF** Switch **ON** (Figure 4 Item 2).
3. **DO NOT** operate the camera system in salt water, acidic or contaminated wells. Whenever the camera and cable have been exposed to acidic or brine water, be sure to wash immediately after use with fresh water.
4. **DO NOT FORCE CONNECTIONS. OBSERVE ALL KEYWAYS ON CONNECTORS AND CABLE HEAD TO PREVENT DAMAGE.**
5. **CAUTION** Before connecting Power to the Control Unit be sure the REEL CONTROL Power ON-OFF Switch is OFF (Figure 4 Item 1), CAM CONTROL ON-OFF Switch is OFF (Figure 4 Item 2), SPEED Control is set to MIN (Figure 4 Item 4), and FORWARD-STOP-REVERSE Switch is at the STOP or center position (Figure 4 Item 3).
6. You **CANNOT** switch between **DOWN VIEW** and **SIDE VIEW** while the Camera is rotating.
7. Loss of power will reset the On-Screen Counter.
8. Store the camera system in an indoor, dry, temperature-controlled environment. Preferably in the provided carry case. **DO NOT** expose the camera system to extreme temperatures during use or storage.
9. **CAUTION:** The Control Unit is **NOT** water proof when open. Take measures to prevent water intrusion during use.
10. **DO NOT** exceed the minimum bend radius of 4" on the cable or cable head. Excessive bending and kinking will damage the cable and cable head.
11. At least ten wraps of the Cable should always be left on the Reel Assembly Cable Drum at maximum depths
12. **DO NOT** overtighten the cable head. Finger tighten when threading the cable head into the camera, a wrench is not necessary.

## Maintenance Instructions

- Ensure the cable head is properly secured during transport and storage.
- Regularly inspect the cable head o-ring condition and o-ring seal area for cleanliness. This area should be free of debris and lubricated as needed.
- The cable head will experience normal wear during use and will need to be replaced at various intervals depending on care and usage. A Cable Head Repair Kit, Part# 126883, is available to replace the cable head in the field as needed. It can be purchased at [www.lavalparts.com](http://www.lavalparts.com) or by calling +1 (559) 251-1396.
- Wash the Camera with fresh water and wipe clean after use. Ensure the camera is free of unwanted oil and contaminants. If necessary, use mild dish soap to clean the camera.
- Prior to and after conducting each survey, inspect the glass ports on the side-view and down-view for any cracks or debris in crevices. If necessary, use household glass cleaner to clean the viewing ports.
- Inspect the cable head connection point at the top of the camera before connecting the cable head to the camera. This area should be clean, free of debris, and the pins should be in the upright position. If the pins are bent or deformed, do not attempt to connect the cable head.
- When not in use store the system in an indoor, temperature-controlled environment in the carry case and foam pads provided.
- Guide the cable evenly across the drum and wipe clean when spooling to prevent contamination, build-up, and damage.
- Keep the Control Unit clean and free of debris. Wipe clean after each use.
- Before use check the lead screw for debris and dirt. Wipe clean as needed.

## Description of Equipment

### Overall

The DW-1500/ DW-2000 Color Video Water Well Inspection System is equipped with two cameras in a single housing, each with a wide-angle lens, for viewing down hole and side view images in water wells or boreholes. Low light level CCD sensors allow the cameras to detect images with minimal lighting power, as low as 1 LUX.

Light Emitting Diodes (LED's) are housed in the Camera and provide lighting for the Down Hole Image and the Side View Image. LED's are shock proof, and long lasting, providing approximately 5000 hours of use.

The Video Output from the Camera duplexes with the control signals and power, going down to the Camera, on a single conductor armored, Kevlar reinforced, coaxial cable. The Camera is therefore operable only with the R-Cam Control Unit supplied with the System and is not compatible with other types of closed circuit survey systems.

A single coaxial Cable head Connector on the rear of the Camera is connected to the Cable by a watertight pressure rated connector.

The R-Cam Control Unit provides all the controls to operate the Camera and Reel Assembly, equipped with a 9" LCD Color Video Monitor, and embedded DVR with internal memory.

A standalone power generating system, which supplies 115 VAC or 220 VAC (specified at time of order) must be used to power to the Winch. The Control Unit is then powered by a 12 VDC power supply from the 12 VDC output plug on the Winch.

### Camera

The Camera, shown in Figure 6, electronics and LED lighting are housed in a stainless steel outer housing (Figure 7 Item 8), which when assembled is water tight at external pressures of 500 PSI.

The Down View Port (Figure 7 Item 5) protects the downhole view lens and LED lighting. The Side View Pyrex Glass Port (Figure 7 Item 7) protects the side view lens and LED lighting.

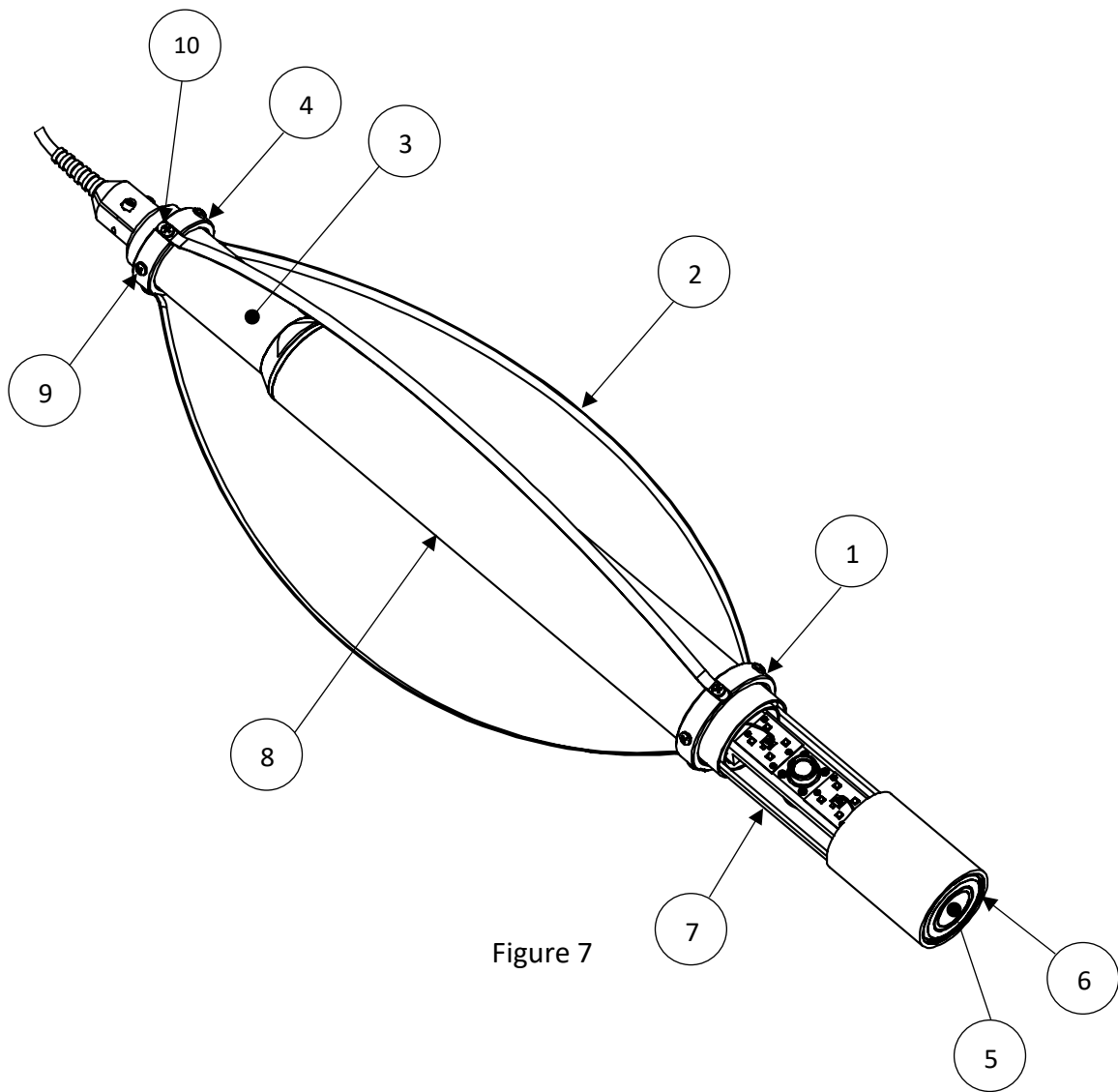

Figure 7

1. Lower Centering Band Collar
2. Centering Bands
3. Thread Protector and Support Tube
4. Upper Centering Band Collar
5. Down View Lens Port
6. Down View LED Lighting Port
7. Glass Side View Lens and LED Lighting Port
8. Camera Housing
9. Set Screw for Centering Band Collar
10. Screw for Centering Band

## Winch

The custom Winch (Figure 8) supplied by Laval Underground Surveys (LUS) is manufactured for operating LUS video camera systems in water wells, boreholes, etc. The Winch is driven by a low speed, high torque electric motor (Figure 8 Item 1). Electric motor power sources for Winch operation are 115V or 220V AC 60/50 Hz (specified at time of order) or an AC generator.

Winch speed and direction are controlled by the variable speed controller built into the Winch Motor Controller (Figure 8 Item 2).

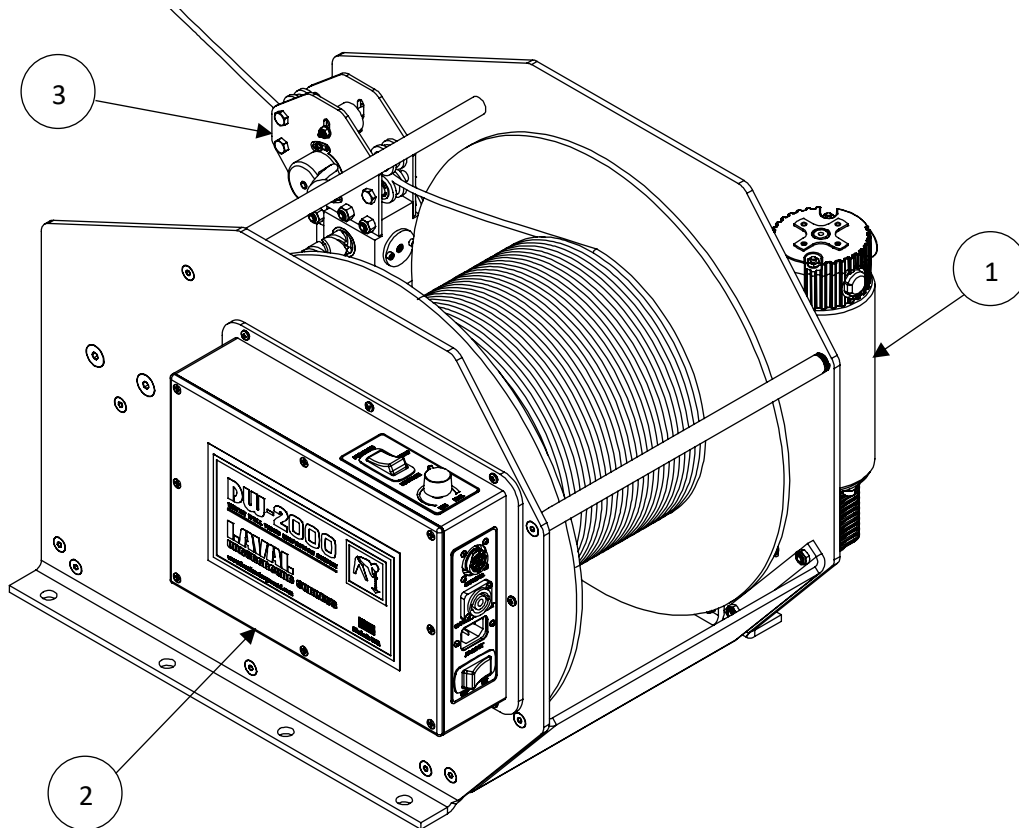

Figure 8

## Counter-Sheave Assembly

A Counter-Sheave Assembly (Figure 8 Item 3) travels back and forth on a Lead Screw to level the Cable as it winds onto the Spool. The sheave drives an electronic Encoder that provides input for the footage counter display on the monitor.

## Control Unit

The R-CAM XLT Control Unit is a lightweight portable, hard case that houses the 9" LCD Monitor Video display with DVR and all the necessary electronics, to control and operate the Camera in a lightweight, portable, hard cover, carrying / storage case.

The front panel controls on the Control Unit are shown in Figure 9.

**NOTE: THE DW-1500/DW-2000 WINCH MUST BE SUPPLIED BY EITHER 115 VAC OR 220 VAC 60Hz/50 Hz. WINCH INPUT POWER VOLTAGE MUST BE SPECIFIED AT TIME OF ORDER.**

12 VDC power is supplied to the control unit from the DW-1500/DW-2000 Winch 12 VDC output.

**NOTE: The REEL CONTROL functions of the Control Unit will NOT operate the Winch Motor Control Functions and WILL disrupt power to the Camera if switched ON.**

The ON-OFF Switch (Figure 9 Item 5) routes power to the Camera and the Camera LED lighting when switched to the ON position.

The FORWARD-REVERSE Switch (Figure 9 Item 6) rotates the Camera's Side-View and Down-View images, and is spring loaded to the STOP (center) position when released.

The VIEW-LIGHT Switch (Figure 9 Item 7) controls the image and light to be viewed on the LCD Monitor, and is spring loaded to the center position when released. Pressing VIEW toggles between "DOWN VIEW" and "SIDE VIEW" on the Monitor. Pressing LIGHT cycles through 5 preset light intensities or levels. The "DOWN VIEW" light intensity is independent of the "SIDE VIEW" light intensity and do not have to match.

The CLEAR Switch (Figure 9 Item 8) is used to set the depth counter to zero (000.00f) after positioning the Camera near the top of the well prior to the start of the survey.

**For DVR set-up and connections, see DVR GUIDE on page 12**

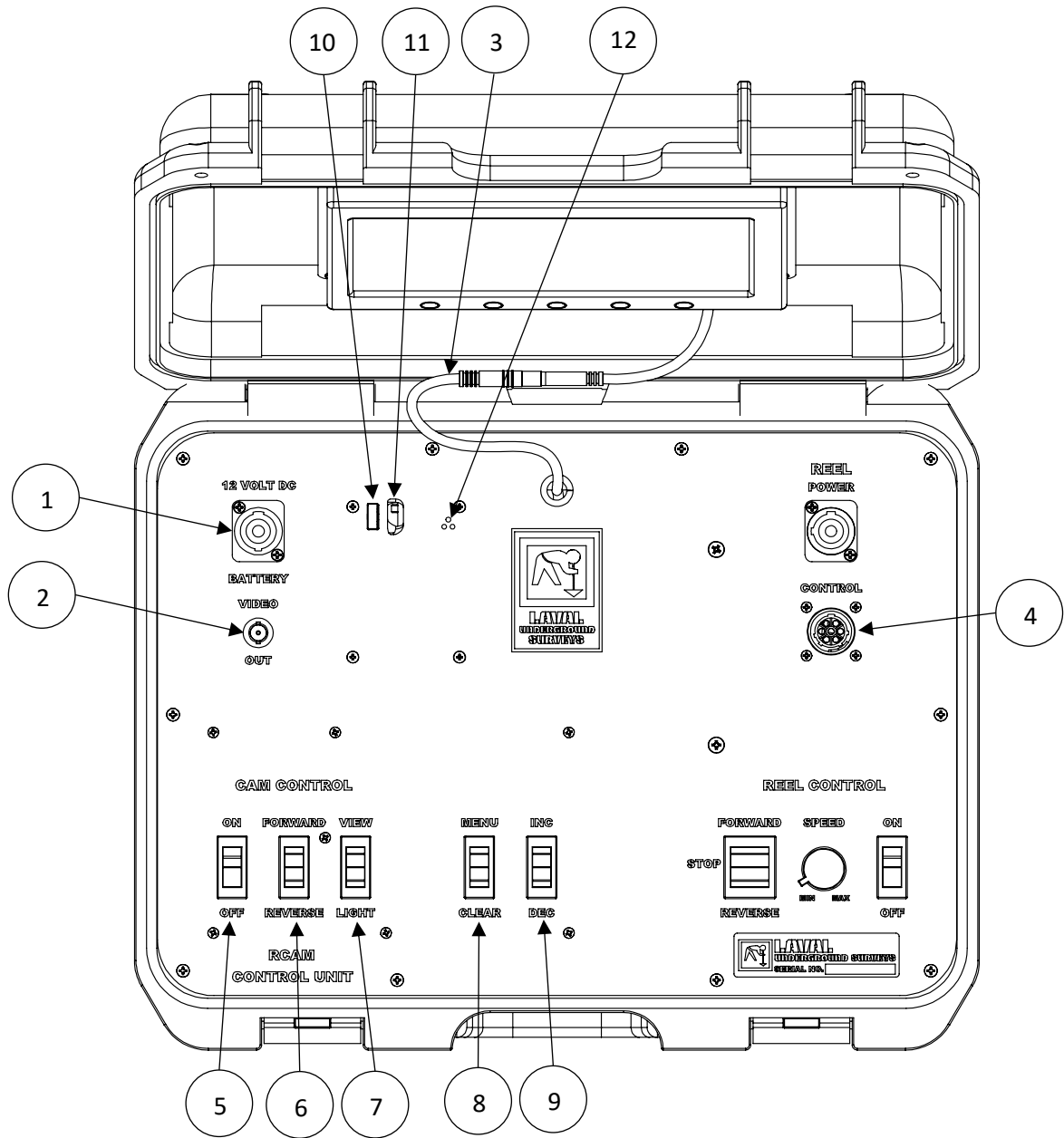

Figure 9

- |  |   |
|--|---|
| <ol style="list-style-type: none"> <li>1. 12 VDC power input connector</li> <li>2. Video Signal output connection to external Video input</li> <li>3. Monitor Power cable</li> <li>4. Camera Function, Video, and Depth Encoder connector</li> <li>5. Camera and Control Unit Power ON-OFF Switch</li> <li>6. Camera Rotation FORWARD-STOP-REVERSE Switch</li> </ol> | <ol style="list-style-type: none"> <li>7. Camera VIEW-LIGHT Selector Switch</li> <li>8. MENU and Depth counter reset CLEAR Switch</li> <li>9. Monitor function INC/DEC Switch</li> <li>10. Keyboard USB Input</li> <li>11. Memory USB (Flash Drive) Input</li> <li>12. Embedded Microphone</li> </ol> |
|--|---|

## Winch Motor Control Functions

**NOTE: THE WINCH CONTROLS ARE LOCATED ON THE DW-1500/DW-2000 WINCH. THE REEL CONTROL ON CONTROL UNIT WILL NOT OPERATE THE WINCH MOTOR**

The ON-OFF Switch (Figure 10 Item 6) routes power to the Motor Drive controls when switched to the ON position.

The FORWARD-STOP-REVERSE Switch (Figure 10 Item 1) controls the Cable Drum to either lower or raise the Camera in the well, and is used in conjunction with the SPEED Control. The toggle switch in the "STOP" position will prevent the winch from moving in the forward or reverse direction.

The SPEED Control Dial (Figure 10 Item 2) is used to control the rate at which the Motor Drive plays out or rewinds the Cable. The speed should always be at MIN to start and then returned back to MIN to stop the Motor Drive.

**NOTE: After individual use, the cable windings will NOT look or lay the same as when the unit was delivered from the factory. This is normal and expected. It will NOT affect the proper working of the Cable or Winch.**

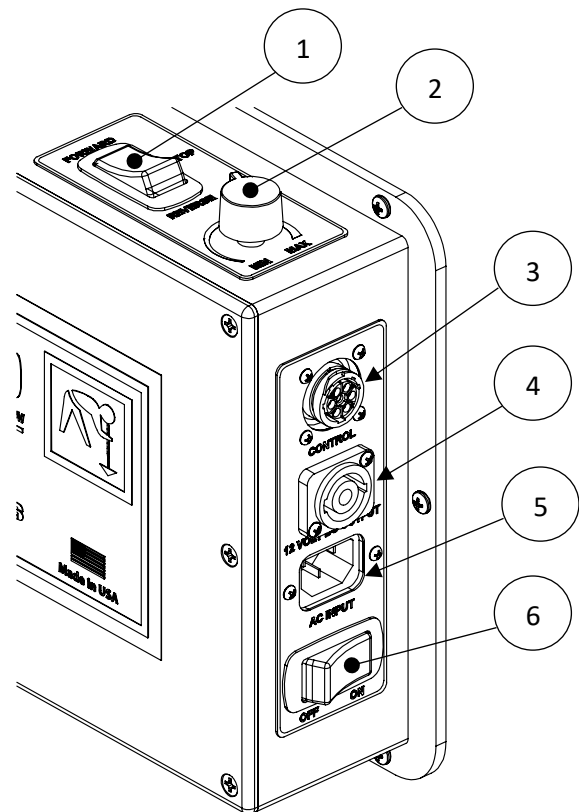

Figure 10



## Adjustments

### Level-Wind Adjustment

If cable windings become uneven, gapped, or bunched, the level-wind Counter-Sheave Assembly (Figure 11 Item 3) should be adjusted. The metal adjustment Knob (Figure 11 Item 1) on the end of the Level-Wind Lead Screw (Figure 11 Item 2) engages and disengages to move the Counter-Sheave Assembly back and forth.

To adjust the level-wind, pull and hold the adjustment Knob (Figure 11 Item 1) out, then turn it to move the Counter-Sheave Assembly so that the level-wind trails (follows) the cable windings on the spool. When correctly adjusted, the cable should lay, wrap by wrap, without gaps, overlays, or bunching.

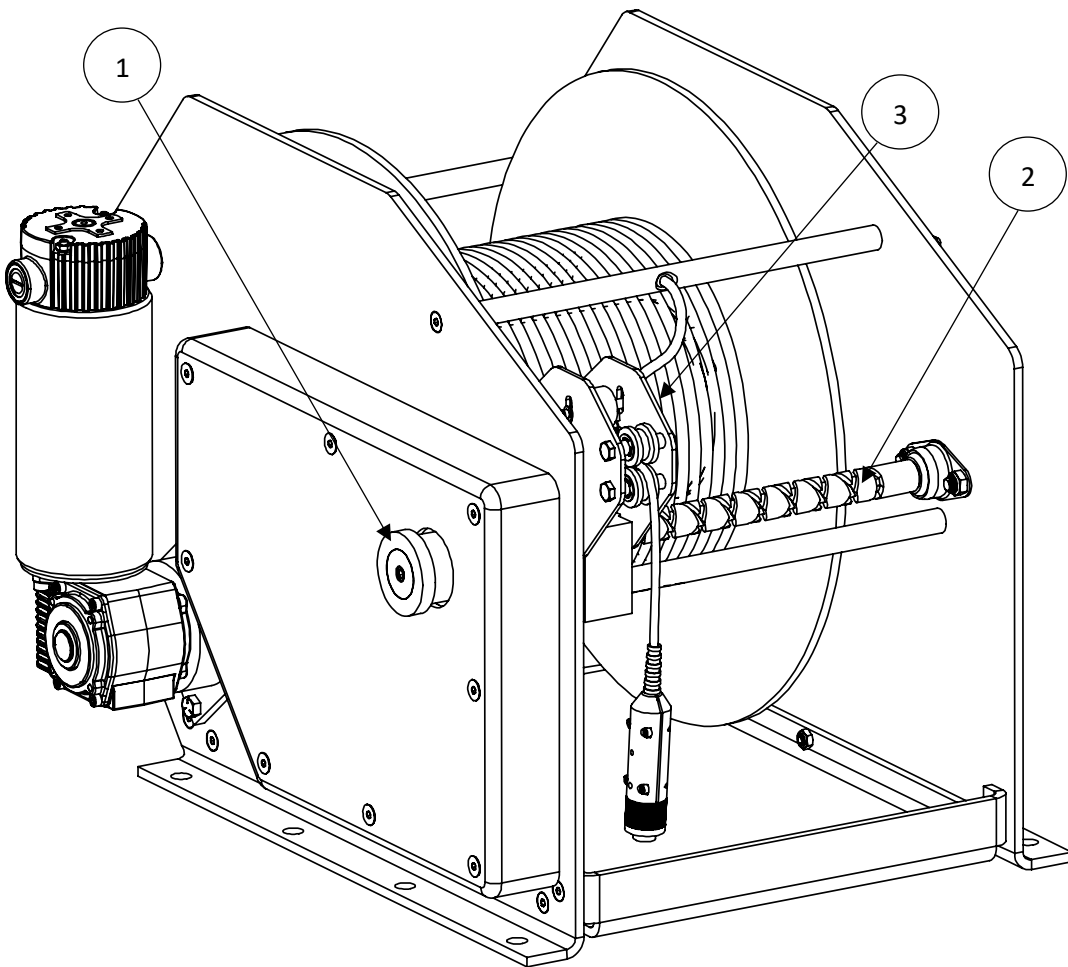

Figure 11

## Level-Wind Key Replacement

With use, the level-wind brass Key (Figure 12 Item 1) that tracks in the level-wind Lead Screw grooves will eventually wear down. To replace the level-wind brass Key:

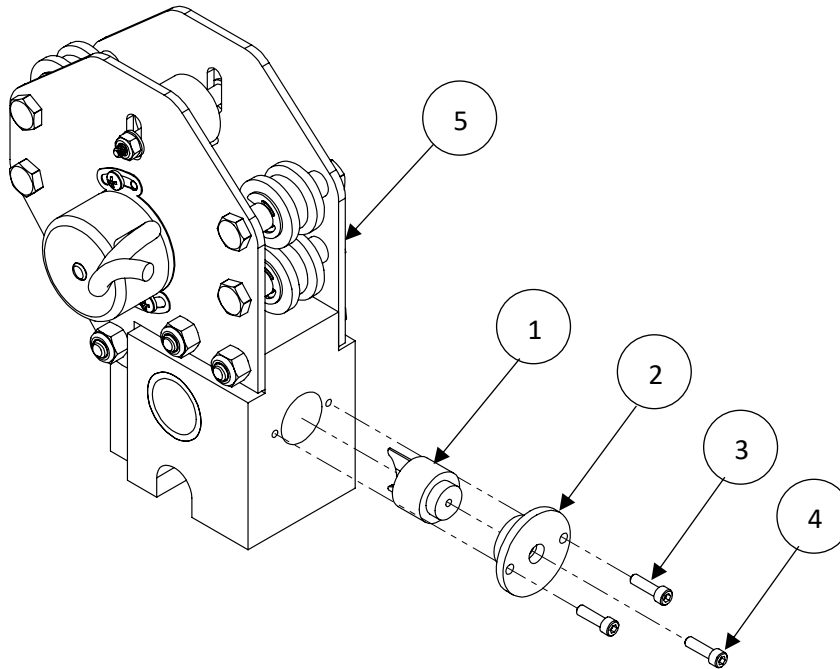

Figure 12

1. Remove the (2) #6-32 socket head bolts (Figure 12 Item 3) that holds down the Keeper (Figure 12 Item 2) and Key (Figure 12 Item 2).
2. Remove the #6-32 socket head bolt (Figure 12 Item 4) that holds the Key to the Keeper.
3. Remove the worn brass Key.
4. Replace the worn brass Key with a duplicate new Key from Laval Underground Surveys.
5. Re-insert and tighten the 6-32 screw (Figure 12 Item 4) back into the new brass Key and Keeper. Make sure Key is secured but spins freely within the Keeper.
6. Re-engage the Keeper and Key into the level-wind Counter-Sheave Assembly (Figure 12 Item 5) and then secure them with the (2) #6-32 screws (Figure 12 Item 3).
7. Check the travel direction of the level-wind and ensure it moves properly by testing level-wind adjustment Knob as directed on the previous page.

## DVR Guide

The Digital Video Recorder (DVR) records video and audio to USB storage media and can capture snapshot images on-the-fly without interrupting recording. It has an internal real-time clock with battery backup that provides date and time information. Videos and snapshots are saved to a folder called DCIM on the USB devices. The DCIM folder is created if not present. The videos are recorded as .ts files and the snapshots are .jpeg files. File names are automatically generated by the real-time clock. The video bit rate can be tailored to match the user requirements and storage capacity.

The recorded audio comes from an internal microphone behind the front panel. The microphone can be muted from recording if desired. Text overlays reflecting current date and time can be applied to appear in the recorded video. A single line of user defined text comments can be overlaid in the video. There are 5 user entered custom text lines.

The DVR has an internal 16GB USB storage device. This internal memory will store at least 8 hours of video. There is a USB jack on the panel for an external storage device. There is no limit on capacity of the USB storage devices; however, the devices need to be FAT 32 format. The DVR will simultaneously record to both the internal and external USB storage devices. **When either internal or external memory becomes full, an on-screen message will prompt the user to address the capacity of the internal or external memory before the recording option will resume.**

There is also a USB jack on the panel for plugging in a standard PC-type USB keyboard. A wireless mini keyboard is supplied with the DVR. There is a black 'receiver' for the provided mini keyboard inserted in a USB space on the control unit. It will have two letters on it that correlate with the mini keyboard. Without the receiver plugged into the control unit, the keyboard will not be able to function. **NOTE:** the keyboard and its USB receiver are paired and cannot be mixed with another set.

### Keyboard Use and Charging

The internal battery is a non-replaceable Polymer Lithium-ion type. If no keys are pressed for more than 3 minutes, the keyboard goes into Sleep Mode. Because of Sleep Mode, the keyboard's battery will last many hours and even many days on one charge. The battery will retain a charge in Sleep Mode from 500 to 700 hours. To re-charge the battery, plug the charging cable into the keyboard and into any standard USB jack. The charging cable can be plugged into the RCAM panel to charge the battery and simultaneously operate the keyboard; however, the keyboard receiver must be plugged in to either the RCAM panel or the female-USB jack on the charging cable. The Green Power LED will flash when the battery power is low. The Red Battery LED will light up when the keyboard is being properly charged.

## Keyboard Functions

<u>Key</u>	<u>Function</u>
<b>Enter or Space Bar</b>	Menu or OK
<b>Up Arrow</b>	Rewind Playback or Move Text Up
<b>Down Arrow</b>	Fast Forward Playback or Move Text Down
<b>ESC (Escape)</b>	Stop/Finalize Recording, Menu Back, or Playback Stop
<b>R</b>	Record Start or Pause Recording
<b>S</b>	Snapshot
<b>M</b>	Mute or Unmute Microphone
<b>P</b>	Pause Record or Playback

<u>Keyboard LED Indicators</u>	<u>Meaning</u>
<b>YELLOW</b>	RF Signal ON=Transmitting
<b>RED</b>	Battery Cable plugged in: ON=charging OFF=Fully charged
<b>GREEN</b>	Power ON=Power on, OFF=Sleep Mode, FLASHING=Low Power
<b>WHITE</b>	CAPS LOCK ON=Caps Lock Active, OFF=Caps Lock Inactive

The DVR is controlled using the keyboard and an on-screen menu system. After initial power-up, press the Space Bar or the Enter key to bring up the Top Menu. Then again press the Space Bar or Enter key to go into one of the Sub Menus.

## Getting Started

To start a recording press **R**. Press **R** a second time to pause a recording, before pressing **R** a third time to resume recording again to create one continuous video. To stop and finalize recordings press **ESC**. Finalization can take up to 2 minutes for long recordings. It is important to note that powering down before stopping/finalizing the recording can result in losing the recording. **A maximum video length of 1.5 hours is recommended to manage file size.** Press **S** at any time to take a snapshot image of the video. To add a text overlay before recording see the Overlays Section on page 18.

## Top Menu:

Play Video

View Snapshots

Overlays

File Management

Setup

Help With Keys

## Play Video

**Play from internal**

**Play from external**

*If only the internal device is present, the files list from the internal device is displayed.*

File selection is made using the up and down arrow keys. Pressing Enter or Space starts playback.

## View Snapshots

Behavior is similar to “Play video”

## Overlays

### **Primary Overlay**

Allows selection of the size of the text from either 8x14 or 16 x 16. You can also select OFF which turns off the text display. The default setting is 16 x 16.

### **Setup Primary Overlay**

#### **Text**

Allows selection of which text is displayed from date only, time only, time and date, custom text 1, custom text 2, custom text 3, custom text 4, or custom text 5. The default setting is time and date.

#### **Custom Text**

Allows the user to enter up to 5 custom text comment lines. Each line has a maximum of 40 characters.

#### **Date Format**

Allows selection of the format of the date display. The default setting is MM – DD – YYYY.

#### **Time Format**

Allows selection of the format of the time display. The default setting is 24 hour format in HH: MM : SS.

#### **Background**

Allows selection of the background of the text from Black, Transparent, 50% black, or 75% black.

**Move Up, Move Down, Move Left, Move Right**

Allows the text to be moved on the screen.

**Secondary Overlay**

Allows selection of Title overlay, Coded overlay, Extra overlay, or off.

**Setup Title/Coded/Extra Overlay**

**Edit Text**

Allows the user to edit the preloaded text

**Load**

Allows the user to edit text that has been saved.

**Save**

Allows the user to keep any changes to the text.

**Text Size**

Allows selection of the size of the text from either 8x14 or 16 x 16. You can also select OFF which turns off the text display. The default setting is 16 x 16.

**Background**

Allows selection of the background of the text from Black, Transparent, 50% black, or 75% black.

**Move Up, Move Down, Move Left, Move Right**

Allows the text to be moved on the screen.

**File Management**

**Copy video from internal**

**Copy video from external**

**Copy snapshots from internal**

**Copy snapshots from external**

**Delete files from internal**

**Delete files from external**

**Rename files on internal**

**Rename files on external**

*If only the internal device is present, the external choices will not be shown.*

## Setup

### **Set Date/Time**

This setting allows for setting up the battery backed-up real-time clock. The real-time clock is used to automatically generate file names for saved video files and snapshots. There is also an option of having the date/time overlay present in recorded video and snapshots.

### **Video**

#### **Video Standard**

Allows selecting between NTSC and PAL video formats.

#### **Interpolate**

Turning interpolation on gets rid of motion artifacts at an expense of some vertical resolution loss. The default setting is ON.

#### **Video Bit Rate**

Determines the compression level of recorded video. The higher the bit rate, the higher is the quality, the more space is required on the storage device. The selection is from 1000kbps to 5000kbps. The default setting is 3500kbps. At the default setting of 3500kbps, a minimum of 8 hours can be recorded onto a 16GB storage device.

#### **Playback Seek**

Adjust the amount of the time skipped when using Rewind and Fast Forward functions. Default is 10.

#### **Snapshot Quality**

Determines the compression level of snapshot. The higher the quality, the more space is required on the storage device. The available settings are 97 (best) down to 50. Default is 90.

#### **Snapshot Overlay**

Turning on this setting allows the text overlay to be shown in Snapshots. Default is On.

#### **Recording Format**

Determines the video format .ts or .mp4. Default is .ts, because there is no loss of data in the event of recording interruption, such as a loss of system power.

### **Audio**

#### **Audio Volume**

Adjusts the microphone sensitivity. The higher the value, the louder the recorded audio. The available settings are from 0 (min) to 10 (max). Default setting is 8.

**Mute Recording at Start**

Automatically mutes the mic at the start of each recording. The user can then unmute the mic during recording when needed. As each new recording is started the mic is muted again. The default setting is ON.

**Audio Input**

Selection is either MIC or LINE. Setting to LINE will decrease the volume level of the recorded mic sound to barely audible. The default setting is MIC.

**Playback Volume**

The available settings are from 0 (min) to 10 (max). Default setting is 10.

**Record Storage Device**

Allows the selecting the recording destination devices: internal, external, or both. The default setting is BOTH.

**Set Language**

Language can be set to English, French, German, Portuguese, or Spanish for the DVR menus only. Default is English.

**System Information**

Displays various system information, including firmware version, detected storage devices with free space available and allows system parameters to be reset, saved and loaded as follows.

**Reset System Parameters**

Resets all the parameter settings to Basic default settings. This option restores the DVR back to the Laval Underground Surveys factory settings.

**Save System Parameters**

Saves all the parameter settings to USB memory storage. *Only use this option if you wish to change the factory settings from Laval Underground Surveys.*

**Load System Parameters**

Loads all the parameter settings from USB memory storage. This option restores the DVR back to the saved settings.

**Turn WiFi on**

Setting allows streaming video over an unsecured network with a WiFi adapter when set up and turned on, for more information on how to set up please contact Laval.



## Helpful DVR Tips

- Press ESC to stop all recordings, playbacks, and to back out of menus. Pausing a recording and powering off will erase the unfinished recording.
- **A MAXIMUM VIDEO LENGTH OF 1.5 HOURS IS RECOMMENDED.**
- Turn the keyboard power off at the end of your use of the system to preserve longer battery life.
- After 3 minutes of not using the keyboard, the keyboard goes into Sleep Mode and all LED indicators will go out. Keys will not work until it wakes up which takes a few seconds. After it wakes up, the Green Power LED will light and the keys will work again.
- If the unit is not operating properly, restoring the setup settings back to Laval Underground Surveys factory settings may fix it. See *“Reset System Parameters” in the System Information section.*
- Monitor available free memory for both the internal and external storage in the System Information screen. If more space is need on the internal storage you can move files to the external storage by copying and then deleting them.
- Stop the movement of the camera (reeling up/down or rotating) when using the snapshot function for clearer pictures.
- Text overlays must be setup and typed in prior to the recording.
- **IMPORTANT**: When renaming video files, do not change or delete the file extension, the “.mp4” or “.ts” part of the name, as this may make the file in-accessible to the system. All video files must have the “.mp4” or “.ts” at the end of their file name. Likewise, the “.jpg” at the end of snapshots file names must be treated the same.
- Always keep the keyboard and its USB receiver paired together with one system, refer to the serial codes on them in the event that they are mixed with another set.
- Larger storage devices such as external hard drives will most likely need formatting to FAT32 to work with the DVR. Keep this in mind and test recording before going into the field.
- Video files recorded as .ts can be converted if they are not compatible with a video player, using a video converter. Converted files may not play back on the DVR.

## Counter Instructions

In the normal operation mode after powering up the unit, the distance count is displayed on the screen along with the camera picture. The **CLEAR** switch (Figure 9 Item 8) clears the count to 0000.00ft (or 0000.000m).

The **MENU** switch (Figure 9 Item 8) sequences through six on-screen modes as follows:

- Preset** . . . . . Preset specific count
- Position.** . . . . . Position count on screen
- Standard.** . . . . . Standard of Feet or Meters
- CAL by Reel.** . . . . . Calibrate by Reel
- CAL by CNT/REV.** . . . . . Calibrate by count per foot
- Status.** . . . . . Status of Control Unit Temperature and Voltage

**NOTE:** in the normal operation mode, the **INC** and **DEC** switches (Figure 9 Item 9) do not have any function; however, they do perform various functions in the other modes.

### Preset Mode

The Preset mode allows the distance count to be preset to a specific number. This provides a way to initially start counting with a number other than zero.

Preset  
INC: Increment  
DEC: Decrement  
CLR: Zero

The **INC** switch (Figure 9 Item 9) increases the count.

The **DEC** switch (Figure 9 Item 9) decreases the count.

The **CLEAR** switch (Figure 9 Item 8) sets the count to zero.

**NOTE:** Holding down the **INC/DEC** (Figure 9 Item 9) switch causes it to increase or decrease repeatedly.

### Position Mode

The Position mode allows positioning of the distance count to be one of five positions: top left, bottom left, bottom right, top right, or centered.

Position  
INC: CW  
DEC: CCW  
CLR: Home (TL)

The **INC** switch (Figure 9 Item 9) sequentially changes the position by moving the positions in a clockwise sequence.

The **DEC** switch (Figure 9 Item 9) sequentially changes the position in a counter-clockwise sequence.

The **CLEAR** switch (Figure 9 Item 8) sets the position to the 'home' position which is at the top left (TL).

## Standard Mode

The Standard mode allows the distance count unit of measurement to be either feet or meters.

The **INC** switch (Figure 9 Item 9) selects the feet standard.  
The **DEC** switch (Figure 9 Item 9) selects the meters standard.

```
Standard
INC: Feet
DEC: Meters
```

**NOTE:** Standard Feet displayed distance is 4 whole digits with 2 decimal places (0000.00ft). Standard Meter displayed distance is 4 whole digits with 3 decimal places (0000.000m).

## CAL by Reel Mode

The CAL by Reel mode allows for software calibration of the distance measurement system of the reel. The calibration feature makes an automatic adjustment of the distance count based on a calculated calibration adjustment factor determined by the procedure.

```
CAL by Reel (EXT 25ft)
INC: Start
DEC: Set
Menu: Store/Exit
```

The procedure is the following:

1. Mark the cable with a 0-foot starting mark and a 25-foot finish mark.
2. Start the calibration procedure by pressing the **INC** (Start) (Figure 9 Item 9) switch.  
**NOTE:** If meters is desired after calibration, the Standard menu must be used to change back to meters.
3. Position the cable starting mark at a place on the counting roller that is easy to see. Run the 25 feet of cable out through the reel. Be sure the cable has normal tension and wrap around the counting wheel just as there would be with a normal setup. Stop running at the cable finish mark at the same place on the counting roller.
4. Press the **DEC** (Set) (Figure 9 Item 9) switch to set the calibration adjustment factor.
5. Finally press the **MENU** switch (Figure 9 Item 8) to store the calibration adjustment factor and exit out of the calibration menu.

## CAL by CNT/REV Mode

The CAL by CNT/REV mode allows for direct entry of the calibration count per revolutions number. Use of this mode is an alternate method of calibration to the CAL by Reel where a known calibration adjustment factor is desired. Using this mode also allows for no adjustment factor to be used by entering the number as the encoder itself times 4. If no adjustment factor is desired, a number of 20 would be

```
CAL by CNT/REV
INC: Increment 10
DEC: Decrement 1
CLR: Clear to 005
Menu: Store/Exit
```

entered for a 5 pulse-per-revolution encoder. For a 100 pulse-per-revolution encoder a number of 400 would be entered.

The **INC** switch (Figure 9 Item 9) increments the number by 10.

The **DEC** switch (Figure 9 Item 9) decrements the number by 1.

The **CLEAR** switch (Figure 9 Item 8) sets the number to 5. After the desired number is entered, the MENU switch (Figure 9 Item 8) stores and exits this mode.

## Status Mode

The Status mode allows for displaying the control unit power supply voltage and temperature.

The **INC** switch displays the temperature in both Celsius and Fahrenheit. **NOTE:** The acceptable operating temperature range is between 5°C to 50°C (41°F to 122°F).

Status INC: Temperature DEC: voltage
--

The **DEC** switch displays the voltage that is applied to the cable for powering the camera. **NOTE:** The acceptable operating voltage range is between 35.0V and 36.5V.

## Water Well Clarification

- There will be occasional wells containing water too dirty for viewing or photography. This condition is generally caused by colloidal particles (rust, dirt, minerals) in suspension in the water column. Often the dirt will settle out if the well is allowed to stand undisturbed for a period of 12 to 24 hours.
- If settling will not clear the water, replacing the well fluid with clear water is a rapid and safe way to achieve visibility. Even the flow from a garden hose for 4 to 12 hours will clear the well. The plan here is to add at least twice the volume of water in the well rapidly enough to force the dirty water back into the formation. Preferably, the water should be introduced below standing water level to avoid driving entrapped air into the fluid column in the well. If this is not possible, the top 40 to 200 feet of the below-water portion of the well will be full of gas bubbles, interfering with vision or photography. It will take a couple of hours for this area to clear after the water flow has been stopped.
- Turbid well water can be cleared by flocculation. This is a chemical process that forces an ionic exchange, causing the particles to migrate and clump until they are heavy enough to fall out like snowflakes.
- There are many commercial flocculants available that are generally used to clean up boiler water and municipal water supplies. Throughout the world we have found that certain soleplates used in conjunction with an increase in the pH of the well water will work under the greatest variety of conditions. Choose the combination that gives the heaviest flock and fastest clearing.
- Occasionally viewing through well water is hampered by algae or bacteria in the well. Particles are dislodged from the sidewalls by the passage of the camera, and the appearance on the screen or pictures is like being in a heavy snowstorm. Should you notice this occurrence contact Laval Underground Surveys regarding our line of well rehabilitation products, Boresaver.
- When the area you wish to see is buried, an air jet pump can quite successfully be used to remove the overburden. The action of this type of pump is so gradual it clears the adjacent water very well, often leaving the well in condition for immediate viewing.
- Obviously, a well with an actual flow through it, bringing in silt particles, will only clear during “off flow” conditions. This may be due to a season of the year, or in the case of a

well field or common water strata shared with other wells, a particular time of the day when the other pumps are off. Sometimes you can shut off the entire field to achieve a static condition; or in an Artesian field, turn on all the other pumps to stop the muddy flow.

- Falling water generally only creates a problem near the surface because it drives air into the water column.
- Drilling mud in suspension is a very difficult problem, only occasionally curable by flocculation. It may require pumping the well clear.
- Well cleaning chemical and drilling detergents interfere with any chemical clarification process. Again, pumping until clear is the solution.
- Often a layer of oil will be encountered on the top of the water surface, especially when inspecting oil lubricated pump well casings. If oil is anticipated, the outside of the lens view ports can be soaped literally with a Liquid detergent. The Camera visibility will be restricted out of the water, but once the oil layer (often 20 feet deep) is penetrated, the detergent may be washed off the viewing port by raising and lowering the Camera. The oil should be wiped from the Cable and Camera when removing from the well.
- Air bubbles may accumulate on the Lens Port when first entering the water. Raise and lower the Camera until the bubbles are removed.
- Caution should be taken not to operate the R-Cam System Camera in contaminated, acidic, or salt environments. If the R-Cam Camera and Cable is exposed to a contaminated or salt intruded well, all exterior surfaces of the Housing, Kevlar Cable, Cable Head and Centering Bands must be thoroughly cleaned and rinsed with fresh water immediately after being removed. Warranty to the system may be voided if damage occurs as a result.

## Trouble-Shooting

PROBLEM	POSSIBLE CAUSE	REMEDY
<p>Camera not working properly, intermittently, or no power/functions (lights, video, or rotation)</p>	<ol style="list-style-type: none"> <li>1. Damaged Cable Head</li> <li>2. Poor Cable Connections</li> <li>3. Low Power</li> <li>4. Extreme Temperature</li> <li>5. Internal issue</li> </ol>	<ol style="list-style-type: none"> <li>1. Rebuild Cable Head with Cable Head Repair Kit</li> <li>2. Check all connecting cables</li> <li>3. Check power at Cable Head.</li> <li>4. Temperature outside of 32° to 122° F (0° to 50° C).</li> <li>5. Send CU and Camera to Laval</li> </ol>
<p>Winch Motor will not operate</p>	<ol style="list-style-type: none"> <li>1. Low Power</li> <li>2. Defective Winch Motor</li> <li>3. Damaged Forward/Reverse Switch</li> </ol>	<ol style="list-style-type: none"> <li>1. Check power at Cable Head.</li> <li>2. Replace Winch Motor</li> <li>3. CU needs to be sent in to replace switch</li> </ol>
<p>Depth Counter Not Accurate</p>	<ol style="list-style-type: none"> <li>1. Cable Slippage on Roller</li> <li>2. Set Screw(s) in Counter Roller/Encoder is loosened from counter shaft</li> <li>3. Cable is running through a secondary pulley.</li> <li>4. System needs to be calibrated</li> <li>5. Encoder is faulty (very rare)</li> </ol>	<ol style="list-style-type: none"> <li>1. Ensure cable is making contact with roller and top tension roller is not loose. Ensure cable on spool is even and laid nicely.</li> <li>2. Check and Correct</li> <li>3. Ensure cable is running straight down from counter pulley before reaching the secondary pulley.</li> <li>4. Follow steps to Cal by Reel in current set up</li> <li>5. Send Winch or Encoder into Laval</li> </ol>

<p>Monitor has “No Signal”</p>	<ol style="list-style-type: none"> <li>1. Damaged Cable Head</li> <li>2. Low Power</li> <li>3. Wrong Monitor Input Selected</li> <li>4. Internal issue</li> </ol>	<ol style="list-style-type: none"> <li>1. Rebuild Cable Head with Cable Head Repair Kit</li> <li>2. Check power at Cable Head.</li> <li>3. Ensure Monitor Input AV 1/Channel 1 is selected from Monitor menu</li> <li>4. Send CU and Camera to Laval</li> </ol>
<p>Monitor has no Power</p>	<ol style="list-style-type: none"> <li>1. Low Power</li> <li>2. Monitor plug is not connected correctly</li> <li>3. Internal Issue</li> </ol>	<ol style="list-style-type: none"> <li>1. Check power at Cable Head.</li> <li>2. Check Monitor plug (above panel) and ensure it is connected properly</li> <li>3. Send CU to Laval</li> </ol>
<p>Video will not Playback</p>	<ol style="list-style-type: none"> <li>1. Cannot Replay Video on Control Unit or Computer</li> <li>2. Menu is not showing up on screen</li> <li>3. No recordings found on control unit after survey</li> </ol>	<ol style="list-style-type: none"> <li>1. Files may be corrupted. Recording may have not saved properly or there was not enough space. Remove files to make more space and retry, saving video by pressing ESC.</li> <li>2. Keyboard may not be charged. Make sure keyboard is charged properly and black receiver is plugged into Control Unit.</li> <li>3. Recording was not saved properly. See page 13 for instructions on properly saving video.</li> </ol>



## WARRANTY

LAVAL UNDERGROUND SURVEYS warrants all products and materials manufactured by it and described herein to be free from defects in workmanship and materials for a period of one year from date of shipment, with the exceptions of fuses, improper battery maintenance, connectors, plugs, cable head, and the Imager.

Any article not manufactured by LAVAL UNDERGROUND SURVEYS and described herein is sold with only such warranties as are made by the manufacturer thereof. No other warranties expressed or implied, of merchantability, fitness for a particular purpose, or otherwise, are made by LAVAL UNDERGROUND SURVEYS other than those set out in the immediately preceding paragraphs.

All repairs shall be made by LAVAL UNDERGROUND SURVEYS at its factory or as otherwise authorized by LAVAL UNDERGROUND SURVEYS in writing. All unauthorized repairs will void warranties.

Warranty is void on any equipment that is abused, modified, or mishandled by customer.

2476 NORTH BUNDY DR. | FRESNO, CA 93727 USA  
TEL: (559) 251.1396 | FAX: (559) 251.2096  
EMAIL: [INFO@LAVALUNDERGROUND.COM](mailto:INFO@LAVALUNDERGROUND.COM)  
WEBSITE: [WWW.LAVALUNDERGROUND.COM](http://WWW.LAVALUNDERGROUND.COM)